



BILFINGER BERGEN
Industriell Service

BIS Industrier

Agenda – Erfaringer og utfordringer innen ISO fagene

- BIS Industrier AS - hvem vi er
- ISO fagene – hva vi gjør
- Erfaringer og utfordringer
 - Klimatiske
 - LNG-prosessanlegg
 - Ressurser og kompetanse

Decorative border of small circles at the bottom.

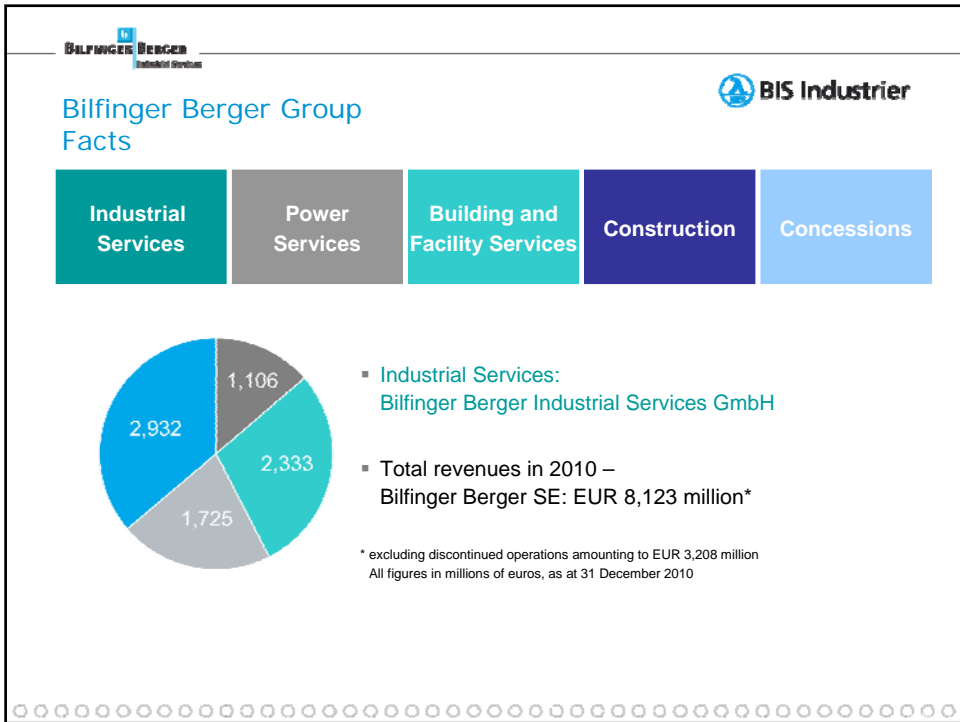

European and international presence

Industrial Services ¹

Employees ²

¹ Total revenues December 2010 before consolidation: Total revenues EUR 3.1 bn.; Consolidated revenues December 2010: EUR 2.9 bn.
² Total headcount 2010: 28,000

- The group of mid-size companies:
- Around 130 sites across Europe and in North America
 - Cross-border collaboration
 - Decentralised operating responsibility
 - BIS management participation system a success model

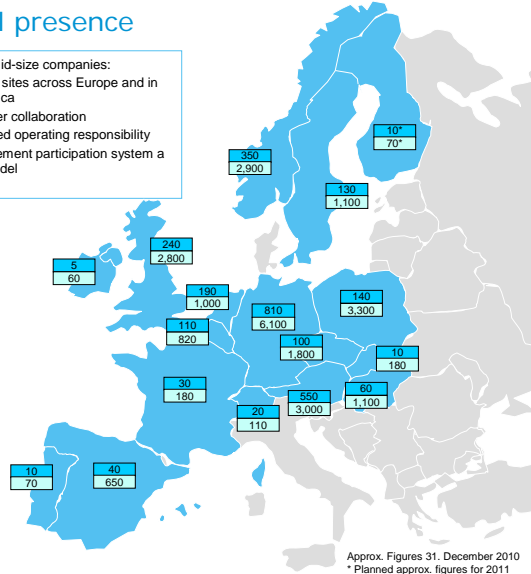

BIS Industrier AS – Lokasjoner og Nøkkeltall

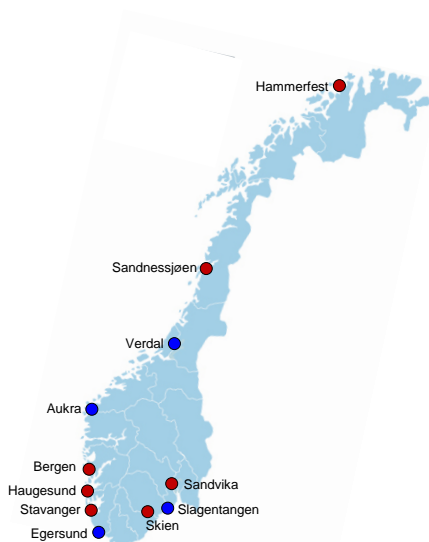

Omsetning 2010	> NOK 1.2 Milliarder
Ansatte	1 300

Lokasjoner Norge	Stavanger Haugesund Bergen Hammerfest Skien Sandvika Sandnessjøen Egersund Aukra Slagentangen Verdal
Hovedkontor	Stavanger

- BIS Industrier kontorer
- BIS Prosjektlokasjoner (Onshore)

BIS Industrier - Region Hammerfest

- ISO Vedlikeholdskontrakt med Statoil på Melkøya siden 2006
- Varighet inkl opsjoner - 2017
- Rekrutterer fagpersonell fra Finnmark/Hammerfest
- 50-60 ansatte i normal drift
- Fokus på HMS og faglig opplæring av lokalt ansatte
- Pr. i dag 120 BIS ansatte på prosjektet, herav 24 lokalt ansatte.
- Mange tilreisende i rotasjon, innleie



Tjenester

Isolering



Stillas og Tilkomst



Overflatebehandling



Passiv Brannbeskyttelse



Teknisk rengjøring



Arkitekt & Innredning



Engineering



Prosjektledelse



BIS Kompetansesenter



Oversikt over rapporterbare personskader 2010 (medisinsk behandling og alternativt arbeid)

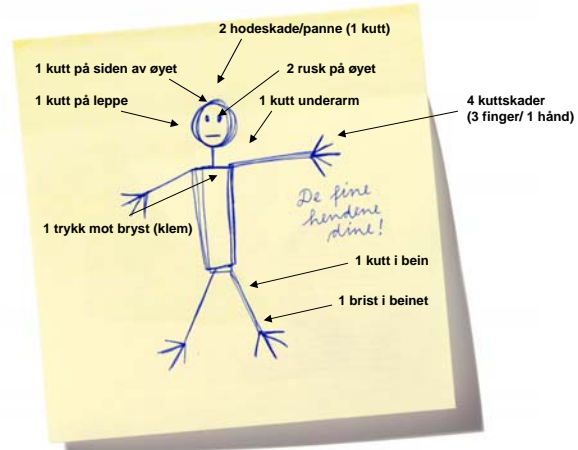

HMS Kampanje 2011



Klimatiske utfordringer



(Foto: Alan Klo, 2006)



(Foto: Mari Hornmedal, 2006)



(Foto: Roar Fredriksen, 2006)

Klimatiske begrensninger

- Overflatebehandling –
 - Avhengig av temperatur: tørketider, påføring
 - mai → september
- Isolasjon
 - Kjerneperiode mai → september
 - Kan utføres gjennom året
 - Utfordringer ved verktøybruk / hansker
- Stillas
 - Følger Overflate og Isolasjon
 - Øvrig vedlikehold / modifikasjonsarbeid
 - Vær og Vind – ising og innfesting
- Kampanjer / Revisjonsstanser
 - Ujevn bemanning

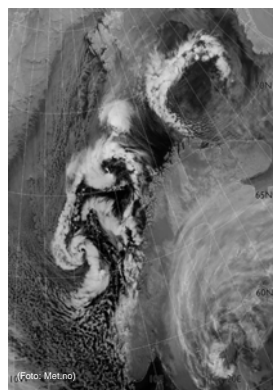

(Foto: Metro)

Lambda Cryo Box

- Effektiv installasjon
 - Færre operatører
 - Prefabrikkert
- Gjenbruk
- Ikke varmt arbeid

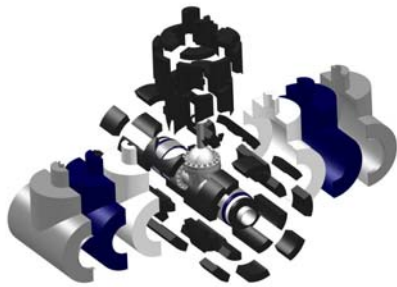

Konvensjonell Cryo-isolering

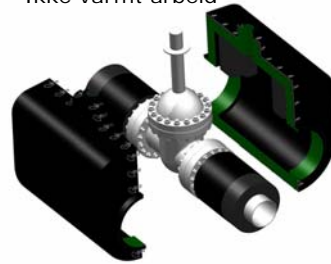

Lambda Cryo Box



Ising rundt ventilstem



Lambda stemforlenger

- Gir full isolasjonstykkelse
- Bryter kuldebroen
- Lufttett gjennomføring
- "ingen ising"

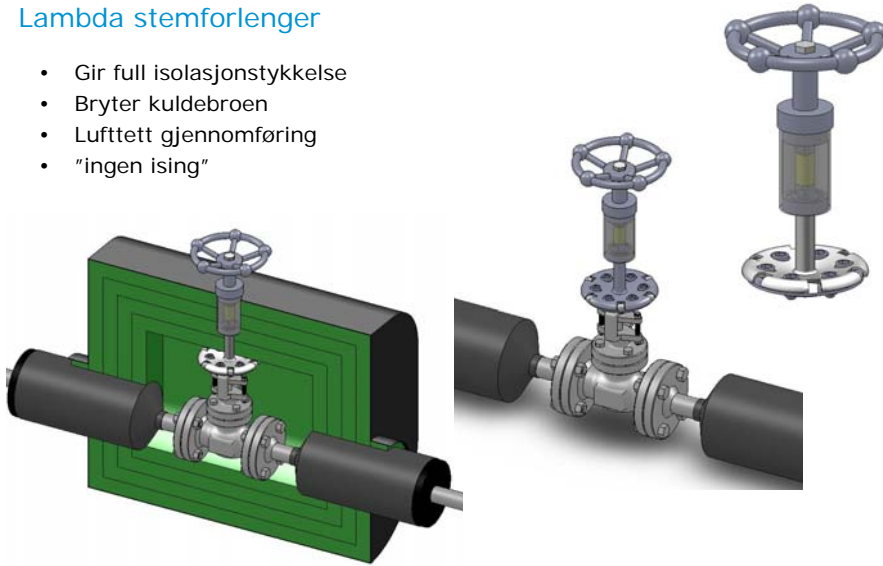

Ressurser og kompetanse

Engineering – Top 20 arbeidsgivere (Universum Student Survey 2010)

Company	Ranking 2010
Statoil	1
Aker Solutions	2
Sintef	3
Det Norske Veritas	4
Statkraft	5
Hydro	6
Norconsult	7
Rambøll	8
Multiconsult	9
SWECO	10
Skanska Norge	11
Kongsberg Gruppen	12
Schlumberger	13
ConocoPhillips Norge	14
Rolls-Royce	15
Forsvarets forskningsinstitutt	16
Statens vegvesen	17
FMC Technologies	18
Shell	19
Reinertsen	20

Kompetansebygging – Hammerfest ISO

- Utfordringer
 - Tilgang på lokal arbeidskraft
 - HMS
 - Kundekrav – andel fagbrev
 - Revisjonsstanser
 - Migrering i verdikjeden
- 18 Fagbrev 2008 - 2011
 - 4 Isolatør
 - 3 Industrimaler
 - 11 Stillasbyggere
- 4 lærlinger 2011
 - 1 Isolatør
 - 1 Industrimaler
 - 2 Stillasbyggere

BIS Kompetansesenter

- Etablert for å sikre tilgang på kompetanse
- Cirka 1400 personer kurses hvert år
 - Ansatte, kunder og konkurrenter
- Bidratt til cirka 1100 fagbrev etter starten
- Opprettet omtrent 150 lærlingeplasser innen våre disipliner
 - I dag har vi 42 lærlinger, fordelt på
 - Stillas – 12
 - Industrimaler – 15
 - Isolatører - 15
- Videreutvikle operatører til flerferdighet



Oppsummering - utfordringer

- Klimatiske utfordringer –
påvirkning på våre
disipliner
- Prosessanlegg – design
og løsninger
- Ressurser og kompetanse
– tiltrekke oss, utvikle og
holde på gode ressurser

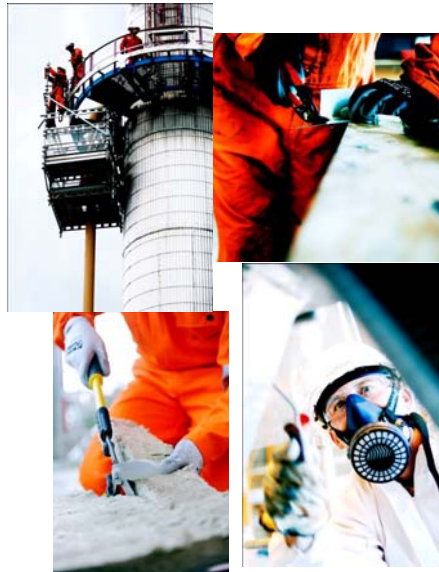

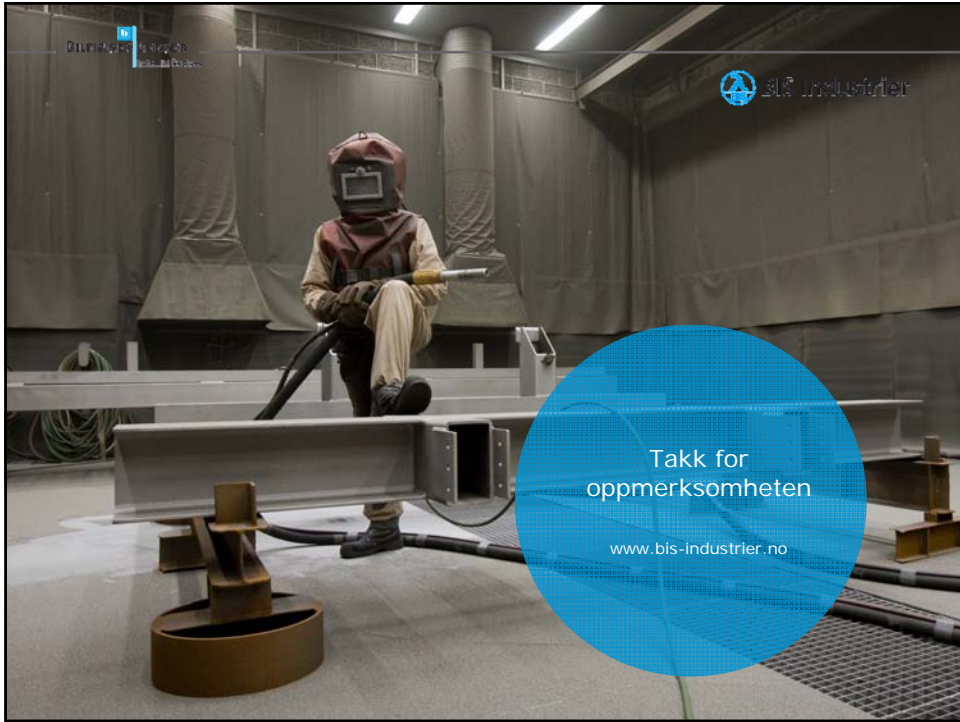

Takk for
oppmerksomheten

www.bis-industrier.no